



Fusionsolar

Commercial & Industrial Smart PV Solution

SOLAR.HUAWEI.COM



About Huawei

Huawei is a leading global provider of information and communications technology (ICT) infrastructure and smart devices. With integrated solutions across four key domains – telecom networks, IT, smart devices, and cloud services – we are committed to bringing digital to every person, home and organization for a fully connected, intelligent world. Huawei's end-to-end portfolio of products, solutions and services are both competitive and secure. Through open collaboration with ecosystem partners, we create lasting value for our customers, working to empower people, enrich home life, and inspire innovation in organizations of all shapes and sizes. At Huawei, innovation focuses on customer needs. We invest heavily in basic research, concentrating on technological breakthroughs that drive the world forward.



Employees
207,000+



R&D Personnel
53.4%



Countries
170+



Brands Global Brands
86



R&D Investment
4



Most Innovative Companies
8

Commercial & Industrial Smart PV Solution

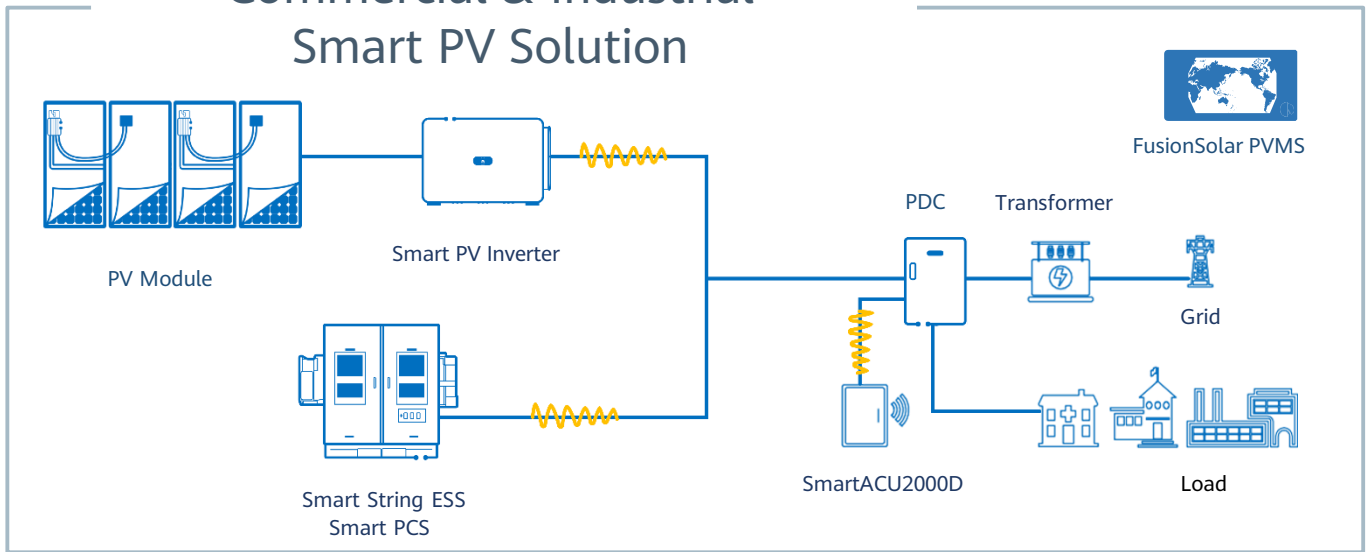

Active Safety	Higher Yields	Maintenance Free
<p>Level 4 AFCI, ahead in the industry</p> <p>0V voltage shutdown</p> <p>4 layer protections</p>	<p>2 Strings per MPPT, More Energy Yields</p> <p>Built-in PID Recovery, Secure Better Module Performance</p>	<p>No Fuse & Other Quick-wear Parts, Inverter Touch Free</p> <p>Online Smart I-V Curve Diagnosis, Module Touch Free</p>



SUN2000-12/15/17/20/25KTL-M5 Smart PV Controller



Active Safety

AI Powered Arcing Protection



Higher Yields

Up to 30% More Energy with Optimizer



Flexible Communication

WLAN, Fast Ethernet, 4G
Communication Supported

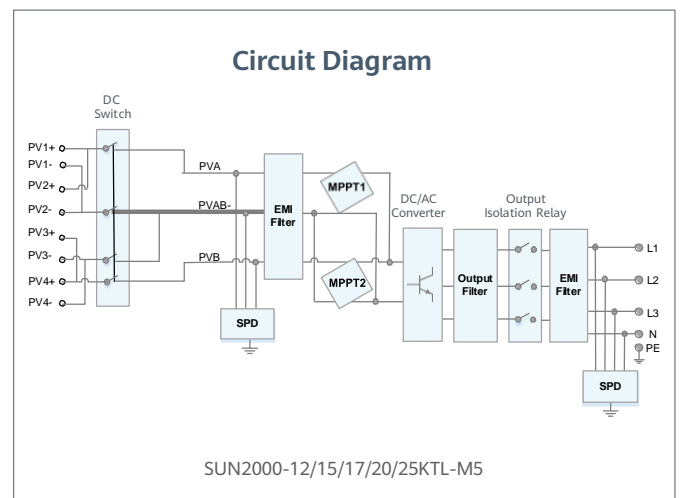
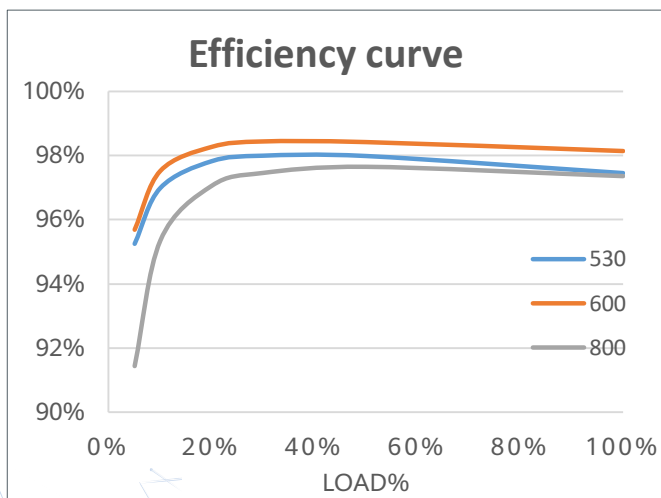

SUN2000-12/15/17/20/25KTL-M5 Technical Specification

Technical Specification	SUN2000 -12KTL-M5	SUN2000 -15KTL-M5	SUN2000 -17KTL-M5	SUN2000 -20KTL-M5	SUN2000 -25KTL-M5
-------------------------	----------------------	----------------------	----------------------	----------------------	----------------------

Efficiency

Max. efficiency	98.4%	98.4%	98.4%	98.4%	98.4%
European weighted efficiency	97.9%	98.0%	98.1%	98.1%	98.2%

Input

Recommended max. PV power ¹	18,000 Wp	22,500 Wp	25,500 Wp	30,000 Wp	37,500 Wp
Max. input voltage ²	1100 V				
Full-load MPPT voltage range	370V~800V	410V~800V	440V~800V	480V~800V	530~800V
MPPT Operating voltage range ³	200 V ~ 1000 V				
Start-up voltage	200 V				
Rated input voltage	600 V				
Max. input current per MPPT	30 A (two string) / 20 A (single string)				
Max. short-circuit current	40 A				
Number of MPP trackers	2				
Max. number of inputs	4				

Output

Grid connection	Three phase				
Rated output power	12,000 W	15,000 W	17,000 W	20,000 W	25,000 W
Max. apparent power	13,200 W	16,500 VA	18,700 VA	22,000 VA	27,500 VA
Rated output voltage	220 Vac / 380 Vac, 230 Vac / 400 Vac, 239.6 Vac / 415Vac, 3W + N + PE				
Rated AC grid frequency	50 Hz / 60 Hz				
Max. output current	18.2A/380Vac 17.3A/400Vac 16.7A/415Vac	25.2A/380Vac 23.9A/400Vac 23.1A/415Vac	28.6A/380Vac 27.1A/400Vac 26.1A/415Vac	33.6A/380Vac 31.9A/400Vac 30.8A/415Vac	42.0A/380Vac 39.9A/400Vac 38.5A/415Vac
Adjustable power factor	0.8 leading ... 0.8 lagging				
Max. total harmonic distortion	≤ 3 %				

Features & Protections

Overvoltage Category	PV II/AC III
Input-side disconnection device	Yes
Anti-islanding protection	Yes
AC over-current protection	Yes
DC reverse-polarity protection	Yes
String fault detection	Yes
DC surge protection	TYPE II
AC surge protection	CLASS II
Residual current monitoring unit	Yes
Arc fault protection	Yes
Ripple control	Yes
Integrated PID recovery ⁴	Yes

General Data

Operation temperature range	-25 ~ + 60 °C (-13 °F ~ 140 °F)
Relative humidity	0 % RH ~ 100% RH
Max. operating altitude	0 ~ 4,000 m (13,123 ft.) (Derating above 2000 m)
Cooling	Smart air cooling
Display	LED Indicators; Integrated WLAN + FusionSolar App
Communication	RS485; WLAN/Ethernet via Smart Dongle-WLAN-FE (Optional) 4G / 3G / 2G via Smart Dongle-4G (Optional)
Weight (with mounting plate)	21kg (46.4 lb)
Dimensions (W x H x D) (incl. mounting plate)	546 x 460 x 228mm (21.5 x 18.1 x 9.0 inch)
Degree of protection	IP66
DC Connector	Staubli MC4

Optimizer Compatibility

DC MBUS compatible optimizer	SUN2000-450W-P2, SUN2000-600W-P, MERC-1100W/1300W-P
------------------------------	---

Standard Compliance (more available upon request)

Safety	EN/IEC 62109-1, EN/IEC 62109-2
Grid connection standards	G99, EN 50549, CEI 0-21, CEI 0-16, VDE-AR-N-4105, VDE-AR-N-4110, C10/11, ABNT, VFR 2019, UNE 217001, UNE 217002, RD 244, TOR D4, IEC61727, IEC62116

^{*1} Inverter max input PV power is 40,000 Wp when long strings are designed and fully connected with SUN2000-450W-P power optimizers.

^{*2} The maximum input voltage is the upper limit of the DC voltage. Any higher input DC voltage would probably damage inverter.

^{*3} Any DC input voltage beyond the operating voltage range may result in inverter improper operating.

^{*4} SUN2000-12~20KTL-M2 raises potential between PV- and ground to above zero through integrated PID recovery function to recover module degradation from PID. Supported module types include: P-type (mono, poly)

SUN2000-30/36/40KTL-M3 Smart PV Controller



Smart

8 strings intelligent monitoring



Efficient

Max. efficiency 98.7%



Safe

Fuse free design



Reliable

Type II surge arresters for DC & AC

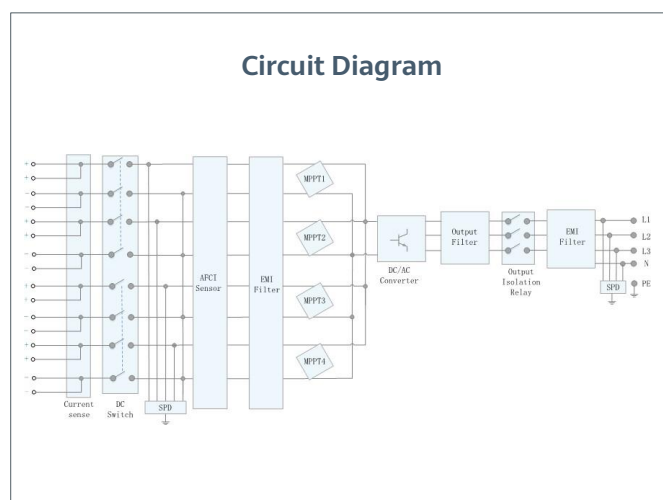
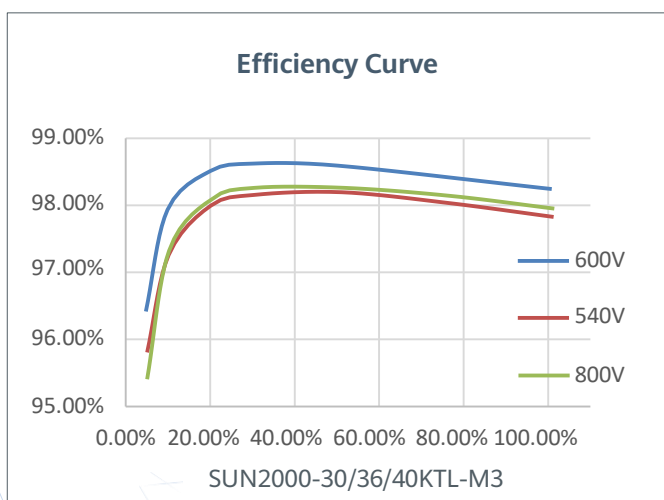

SUN2000-30/36/40KTL-M3
Technical Specification

Technical Specification	SUN2000-30KTL-M3	SUN2000-36KTL-M3	SUN2000-40KTL-M3
-------------------------	------------------	------------------	------------------

Efficiency

Max. Efficiency	98.7%		
European Efficiency	98.4%		

Input

Max. Input Voltage ¹	1,100 V		
Max. Current per MPPT	27 A (per MPPT) / 20 A (per Input)		
Max. Short Circuit Current per MPPT	40 A		
Start Voltage	200 V		
MPPT Operating Voltage Range ²	200 V ~ 1000 V		
Rated Input Voltage	600 V		
Number of Inputs	8		
Number of MPP Trackers	4		

Output

Rated AC Active Power	30,000 W	36,000 W	40,000 W
Max. AC Apparent Power	33,000 VA ³	40,000 VA	44,000 VA
Rated Output Voltage	230 Vac / 400 Vac / 480 Vac, 3W/N+PE		
Rated AC Grid Frequency	50 Hz / 60 Hz		
Rated Output Current	43.3 A	52.0 A	57.8 A
Max. Output Current	47.9 A	58.0 A	63.8 A
Adjustable Power Factor Range	0.8 LG ... 0.8 LD		
Max. Total Harmonic Distortion	< 3%		

Protection

Input-side Disconnection Device	Yes
Anti-islanding Protection	Yes
AC Overcurrent Protection	Yes
DC Reverse-polarity Protection	Yes
PV-array String Fault Monitoring	Yes
DC Surge Arrester	Yes
AC Surge Arrester	Yes
DC Insulation Resistance Detection	Yes
Residual Current Monitoring Unit	Yes
Arc Fault Protection	Yes
Ripple Receiver Control	Yes
Integrated PID Recovery ³	Yes

Communication

Display	LED Indicators, Integrated WLAN + FusionSolar APP
RS485	Yes
Smart Dongle	WLAN/Ethernet via Smart Dongle-WLAN-FE (Optional) 4G / 3G / 2G via Smart Dongle-4G (Optional)

General Data

Dimensions (W x H x D)	640 x 530 x 270 mm (25.2 x 20.9 x 10.6 inch)
Weight (with mounting plate)	43 kg (94.8 lb)
Operating Temperature Range	-25 ~ + 60 °C (-13 °F ~ 140 °F)
Cooling Method	Natural Convection
Max. Operating Altitude	4,000 m (13,123 ft.) (Derating above 2000 m)
Relative Humidity	0% RH ~ 100% RH
DC Connector	Amphenol Helios H4
AC Connector	Waterproof Connector + OT/DT Terminal
Protection Degree	IP 66
Topology	Transformerless
Nighttime Power Consumption	≤ 5.5W

Optimizer Compatibility

DC MBUS Compatible Optimizer	SUN2000-450W-P2, SUN2000-600W-P, MERC-1100W/1300W-P
------------------------------	---

Standard Compliance (more available upon request)

Safety	EN 62109-1/-2, IEC 62109-1/-2, EN 50530, IEC 62116, IEC 60068, IEC 61683
Grid Connection Standards	IEC 61727, VDE-AR-N4105, VDE 0126-1-1, BDEW, G59/3, UTE C 15-712-1, CEI 0-16, CEI 0-21, RD 661, RD 1699, P.O. 12.3, RD 413, EN-50438-Turkey, EN-50438-Ireland, C10/11, MEA, Resolution No.7, NRS 097-2-1, AS/NZS 4777.2, DEWA

1. The maximum input voltage is the upper limit of the DC voltage. Any higher input DC voltage would probably damage inverter.
2. Any DC input voltage beyond the operating voltage range may result in inverter improper operating.
3. SUN2000-30~40KTL-M3 raises potential between PV- and ground to above zero through integrated PID recovery function to recover module degradation from PID. Supported module types include: P-type (mono, poly)

SUN2000-50KTL-M3 Smart PV Controller



Higher Yields

Up to 30% More Energy
with Optimizer



Active Safety

AI Powered
Active Arcing Protection



Flexible Communication

WLAN, Fast Ethernet, 4G
Communication Supported

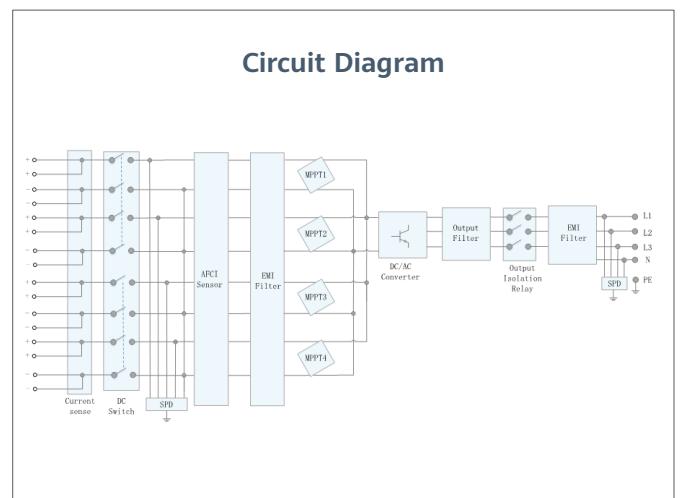
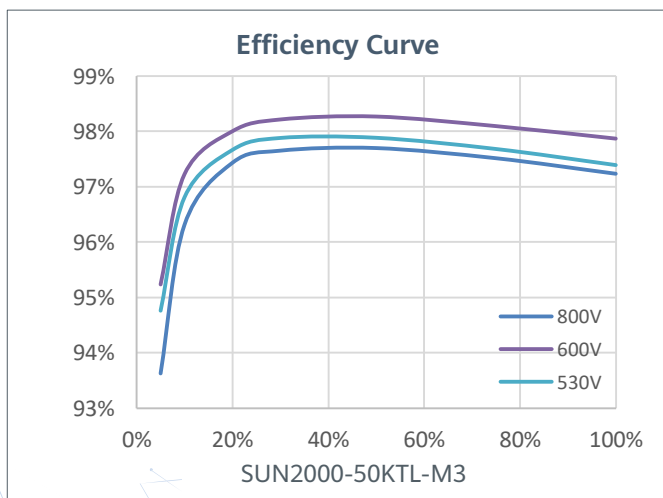

Technical Specification **SUN2000-50KTL-M3**

Efficiency	
Max. Efficiency	98.5%
European Efficiency	98.0%

Input	
Max. Input Voltage ¹	1,100 V
Max. Current per MPPT	30 A
Max. Current per Input	20 A
Max. Short Circuit Current per MPPT	40 A
Start Voltage	200 V
MPPT Operating Voltage Range ²	200 V ~ 1,000 V
Rated Input Voltage	600 V
Number of Inputs	8
Number of MPP Trackers	4

Output	
Rated AC Active Power	50,000 W
Max. AC Apparent Power	55,000 VA
Max. AC Active Power (cosφ=1)	55,000 W
Rated Output Voltage	400 Vac / 480 Vac, 3W+(N) + PE
Rated AC Grid Frequency	50 Hz / 60 Hz
Rated Output Current	72.2 A @ 400Vac, 60.1 A @ 480Vac
Max. Output Current	79.8 A @ 400Vac, 66.5 A @ 480Vac
Adjustable Power Factor Range	0.8 LG ... 0.8 LD
Max. Total Harmonic Distortion	<3%

Protection	
Input-side Disconnection Device	Yes
Anti-islanding Protection	Yes
AC Overcurrent Protection	Yes
DC Reverse-polarity Protection	Yes
PV-array String Fault Monitoring	Yes
DC Surge Arrester	Type II
AC Surge Arrester	Type II
DC Insulation Resistance Detection	Yes
Residual Current Monitoring Unit	Yes
Arc Fault Protection	Yes
Ripple Receiver Control	Yes
Integrated PID Recovery ³	Yes

Communication	
Display	LED Indicators, WLAN + APP
RS485	Yes
Smart Dongle	WLAN/Ethernet via Smart Dongle-WLAN-FE (Optional) 4G / 3G / 2G via Smart Dongle-4G (Optional)
Monitoring BUS (MBUS)	Yes (Isolation Transformer required)

Optimizer Compatibility	
DC MBUS Compatible Optimizer ⁴	MERC-1100/1300W-P

General Data	
Dimensions (W x H x D)	640 x 530 x 270 mm (25.2 x 20.9 x 10.6 inch)
Weight (with mounting plate)	49 kg (108.1 lb)
Operating Temperature Range	-25°C ~ 60°C (-13°F ~ 140°F)
Cooling Method	Smart Air Cooling
Max. Operating Altitude	4,000 m (13,123 ft.)
Relative Humidity	0% RH ~ 100% RH
DC Connector	Amphenol HH4
AC Connector	Waterproof Connector + OT/DT Terminal
Protection Degree	IP 66
Topology	Transformerless
Nighttime Power Consumption	≤ 5.5W

Standard Compliance (more available upon request)	
Safety	EN 62109-1/-2, IEC 62109-1/-2, IEC 62116, IEC 60068, IEC 61683
Grid Connection Standards	IEC 61727, VDE-AR-N4105, VDE 0126-1-1, BDEW, G59/3, UTE C 15-712-1, CEI 0-16, CEI 0-21, RD 661, RD 1699, P.O. 12.3, RD 413, EN-50438-Turkey, EN-50438-Ireland, C10/11, MEA, Resolution No.7, NRS 097-2-1, DEWA

1. The maximum input voltage is the upper limit of the DC voltage. Any higher input DC voltage would probably damage inverter.
2. Any DC input voltage beyond the operating voltage range may result in inverter improper operating.
3. SUN2000-30-50KTL-M3 raises potential between PV- and ground to above zero through integrated PID recovery function to recover module degradation from PID. Supported module types include: P-type (mono, poly), N-type (nPERT, HIT)

SUN2000-100KTL-M2 Smart PV Controller



10
MPP Trackers



98.8% (@480V)
Max. Efficiency



String-level
Management



Smart I-V Curve Diagnosis
Supported



MBUS
Supported



Support AFCI &
Smart String Level
Disconnecter



Surge Arresters for
DC & AC



IP66
Protection

Efficiency Curve

SUN2000-100KTL-M2@400V

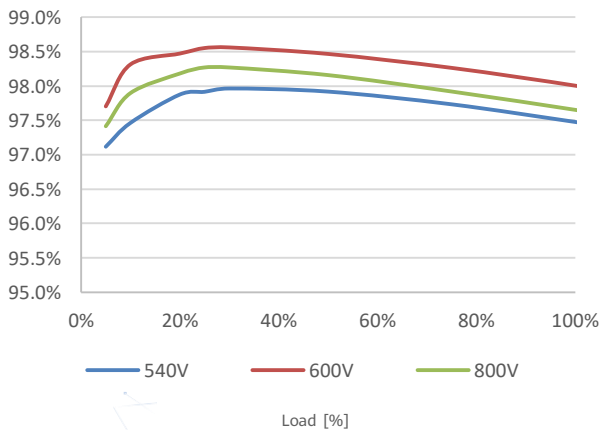

Circuit Diagram

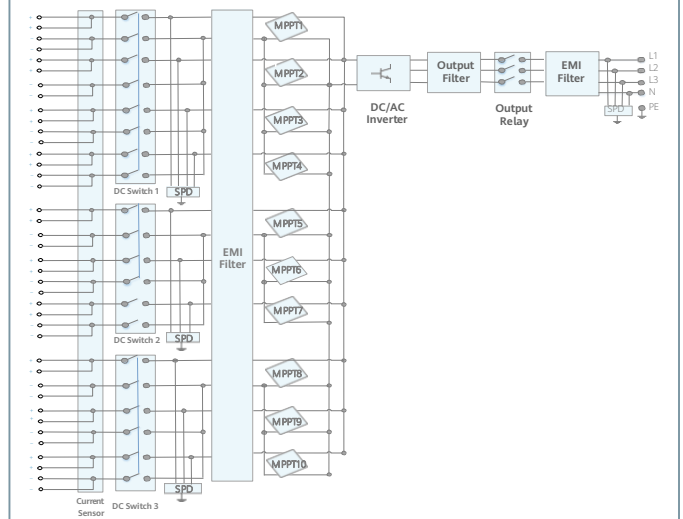

Technical Specification SUN2000-100KTL-M2

Efficiency	
Max. efficiency	98.6% @ 400 V, 98.8% @ 480 V
European efficiency	98.4% @ 400 V, 98.6% @ 480 V

Input	
Max. Input Voltage ¹	1,100 V
Max. Current per MPPT	30 A
Max. Current per Input ³	20 A
Max. Short Circuit Current per MPPT	40 A
Start Voltage	200 V
MPPT Operating Voltage Range ²	200 V ~ 1,000 V
Nominal Input Voltage	600 V @ 400 Vac, 720 V @ 480 Vac
Number of MPP trackers	10
Max. input number per MPP tracker	2

Output	
Nominal AC Active Power	100,000 W
Max. AC Apparent Power	110,000 VA
Max. AC Active Power (cosφ=1)	110,000 W
Nominal Output Voltage	380 V/ 400 V/ 480 V, 3W+(N)+PE
Rated AC Grid Frequency	50 Hz / 60 Hz
Nominal Output Current	144.4 A @ 400 V, 120.3 A @ 480 V
Max. Output Current	160.4 A @ 400 V, 133.7 A @ 480 V
Adjustable Power Factor Range	0.8 leading... 0.8 lagging
Max. Total Harmonic Distortion	< 3%

Protection	
Input-side Disconnection Device	Yes
Anti-islanding Protection	Yes
AC Overcurrent Protection	Yes
DC Reverse-polarity Protection	Yes
PV-array String Fault Monitoring	Yes
DC Surge Arrester	Type II
AC Surge Arrester	Type II
DC Insulation Resistance Detection	Yes
Residual Current Monitoring Unit	Yes
Arc Fault Protection	Yes
Smart String Level Disconnecter	Yes

Communication	
Display	LED indicators; WLAN adaptor + FusionSolar APP
RS485	Yes
USB	Yes
Smart Dongle-4G	Smart Dongle - 4G / WLAN (Optional)
Monitoring BUS (MBUS)	Yes (isolation transformer required)

General Data	
Dimensions (W x H x D)	1,035 x 700 x 365 mm
Weight (with mounting plate)	≤93 kg
Operating Temperature Range	-25°C ~ 60°C
Cooling Method	Smart Air Cooling
Max. Operating Altitude	4,000 m (13,123 ft.)
Relative Humidity	0 ~ 100%
DC Connector	Amphenol Helios H4
AC Connector	Waterproof Connector + OT/DT Terminal
Protection Degree	IP66
Topology	Transformerless
Nighttime Power Consumption	< 3.5 W

Standard Compliance (more available upon request)	
Certificate	EN 62109-1/-2, IEC 62109-1/-2, EN 50530, IEC 62116, IEC 61727, IEC 60068, IEC 61683
Grid Connection Standards	VDE-AR-N4105, EN 50549-1, EN 50549-2, RD 661, RD 1699, C10/11

^{*1} The maximum input voltage is the upper limit of the DC voltage. Any higher input DC voltage would probably damage inverter.
^{*2} Any DC input voltage beyond the operating voltage range may result in inverter improper operating.
^{*3} Single-string access.

SUN2000-115KTL-M2 Smart PV Controller



10
MPP Trackers



98.8% (@480V)
Max. Efficiency



String-level
Management



Smart I-V Curve Diagnosis
Supported



MBUS
Supported



Support
Smart String Level
Disconnecter



Surge Arresters for
DC & AC



IP66
Protection

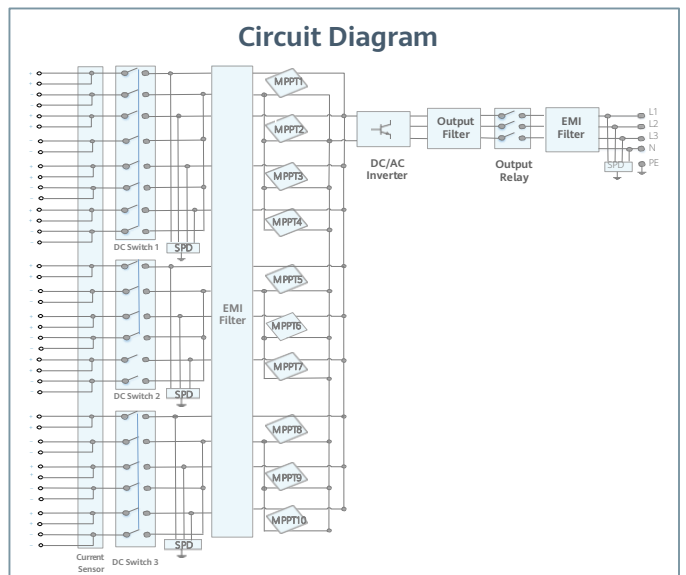
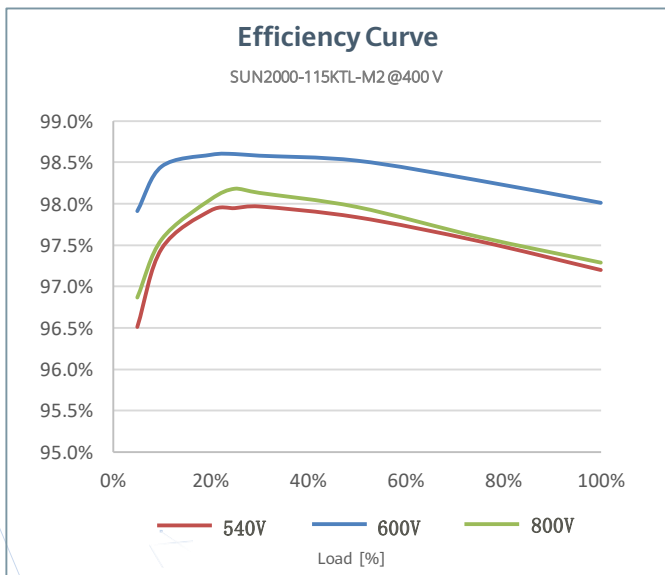

Technical Specification SUN2000-115KTL-M2

Efficiency	
Max. efficiency	98.6% @400 V, 98.8% @480 V
European efficiency	98.4% @400 V, 98.6% @480 V

Input	
Max. Input Voltage ¹	1,100 V
Max. Current per MPPT	30 A
Max. Current per Input	20 A
Max. Short Circuit Current per MPPT	40 A
Start Voltage	200 V
MPPT Operating Voltage Range ²	200 V ~ 1,000 V
Nominal Input Voltage	600 V @400 Vac, 720 V @480 Vac
Number of MPP trackers	10
Max. input number per MPP tracker	2

Output	
Nominal AC Active Power	115,000 W
Max. AC Apparent Power	125,000 VA
Max. AC Active Power (cosφ=1)	125,000 W
Nominal Output Voltage	400 V / 480 V, 3W+(N)+PE
Rated AC Grid Frequency	50 Hz / 60 Hz
Nominal Output Current	166.0 A @400 V, 138.4 A @480 V
Max. Output Current	182.3 A @400 V, 151.9 A @480 V
Adjustable Power Factor Range	0.8 leading... 0.8 lagging
Max. Total Harmonic Distortion	< 3%

Protection	
Input-side Disconnection Device	Yes
Anti-islanding Protection	Yes
AC Overcurrent Protection	Yes
DC Reverse-polarity Protection	Yes
PV-array String Fault Monitoring	Yes
DC Surge Arrester	Type II
AC Surge Arrester	Type II
DC Insulation Resistance Detection	Yes
Residual Current Monitoring Unit	Yes
Smart String Level Disconnecter	Yes

Communication	
Display	LED indicators; WLAN adaptor + FusionSolar APP
RS485	Yes
USB	Yes
Smart Dongle-4G	Smart Dongle – 4G / WLAN (Optional)
Monitoring BUS (MBUS)	Yes (isolation transformer required)

General Data	
Dimensions (W x H x D)	1,035 x 700 x 365 mm
Weight (with mounting plate)	≤93 kg
Operating Temperature Range	-25°C ~ 60°C
Cooling Method	Smart Air Cooling
Max. Operating Altitude	4,000 m (13,123 ft.)
Relative Humidity	0 ~ 100%
DC Connector	Amphenol Helios H4
AC Connector	Waterproof Connector + OT/DT Terminal
Protection Degree	IP66
Topology	Transformerless
Nighttime Power Consumption	< 3.5 W

Standard Compliance (more available upon request)	
Certificate	EN 62109-1/-2, IEC 62109-1/-2, EN 50530, IEC 62116, IEC 61727, IEC 60068, IEC 61683
Grid Connection Standards	VDE-AR-N4105, EN 50549-1, EN 50549-2, RD 661, RD 1699, C10/11

^{*1} The maximum input voltage is the upper limit of the DC voltage. Any higher input DC voltage would probably damage inverter.
^{*2} Any DC input voltage beyond the operating voltage range may result in inverter improper operating.

LUNA2000 - 200/161/129KWH-2H1

LUNA2000 - 97KWH-1H1

Smart String ESS



More Energy



Simple O&M



Safe & Reliable

Energy Storage System Parameters

Model Type	LUNA2000-200KWH-2H1	LUNA2000-161KWH-2H1	LUNA2000-129KWH-2H1	LUNA2000 - 97KWH-1H1
Battery Configuration	12S1P	10S1P	8S1P	6S1P
Maximum battery capacity of the energy storage system	193.5kWh	161.3kWh	129.0kWh	96.8kWh
Max. Charging Power	≤100 kW			
Max. Discharging Power	≤100 kW	≤100 kW	≤100 kW	≤92 kW
Dimensions (W x H x D)	1810mm×2135mm×1200mm			
Dimensions (W x H x D), including Smart Rack Controller and Smart PCS	2570mm x 2135mm x 1200mm			
Weight (including the battery pack)	≤2950kg	≤2690kg	≤2430kg	≤2170kg
Weight (without the battery pack)	≤1070kg	≤1070kg	≤1090kg	≤1130kg
Operating temperature range	-30 °C ~ 55 °C			
Storage temperature range	-40 °C ~ 60 °C			
Operating humidity range	0 ~ 100% (non-condensing)			
Maximum operating altitude	4,000 m			
Installation Environment Requirement	Outdoor installation			
Battery temperature control mode	Industrial-grade air conditioner			
Fire suppression of energy storage system	YES			
Auxiliary Power Supply	220Vac, ≤4.2kW			
Communication port	Ethernet / SFP			
Communication protocol	Modbus TCP			
Protection degree	IP55			
EMC Protection Rating	ClassA			
DC Lightning Protection	Type II			
Standards				
Environment	RoHS			
Certification Standards	GB/T 36276-2018; GB/T 33582; UL9540A; UN38.3; ISO 9227:2017; IEC 60529; IEC/EN 62477-1 IEC/EN 62040-1; IEC/EN 61000-6-2; IEC/EN 61000-6-4; EN 55011;			

Battery Pack & Smart Rack Controller Smart String ESS



Battery Pack		
General		
Model Type	LUNA2000-200KWH-2H1	LUNA2000 - 161/129KWH-2H1 LUNA2000 - 97KWH-1H1
Cell Material	LFP	
Nominal Capacity	16.13 kWh	
Supported Charge & Discharge Rate	≤0.5C	≤1C
Weight	≤ 140 kg	
Dimensions (W x H x D)	442 x 308 x 660 mm	



Smart Rack Controller	
Efficiency	
Max. Efficiency	≥ 98.5%
Battery Side	
Rated Voltage	691.2 V
Operating Voltage Range	40 V ~ 1,050 V
Min. Start Voltage	350 V
Bus Side	
Max. DC Voltage	1,100 V
Rated Voltage	665 V
Rated Current	76.3 A
General	
Dimensions (W x H x D)	600 x 820 x 270 mm
Weight	≤ 90 kg
Cooling Method	Smart Air Cooling
Protection Degree	IP66

LUNA2000-100KTL-M1 Smart PCS



Surge Arresters for
DC & AC



Modular Design



IP66 Protection



Ethernet
Communication



Smart Grid
Algorithm

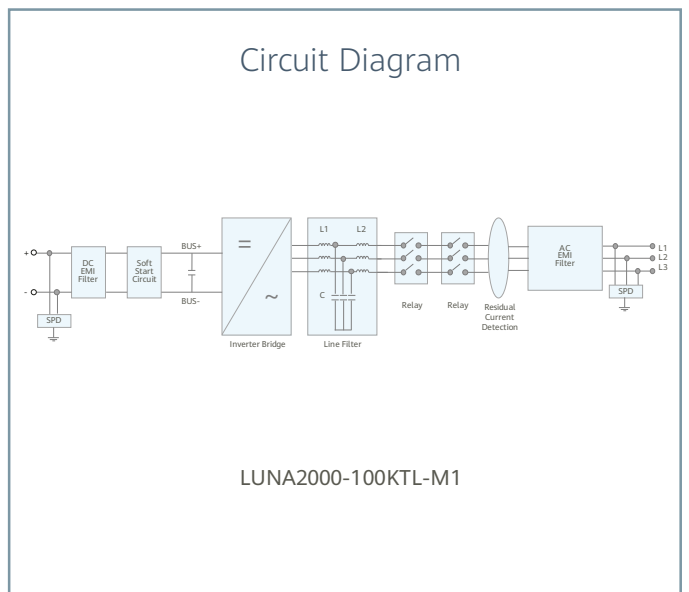
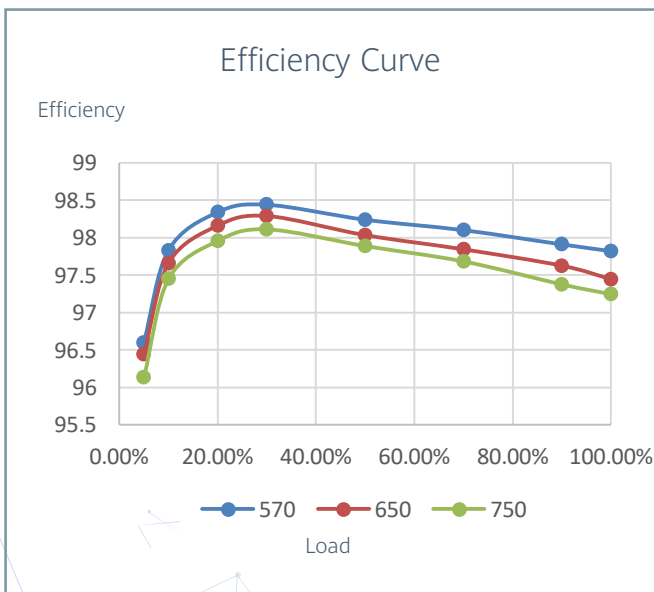

LUNA2000-100KTL-M1

Technical Specifications



Efficiency	
Max. Efficiency	98.4%
DC Side	
Rated DC Voltage	645 V
Max. DC Voltage	1,100 V
Operating DC Voltage Range	570 V ~ 1100 V
Max. DC Current	215.8 A
Max. Number of Inputs	1
AC Side	
Rated AC Active Power	100k W @40°C
Rated AC Voltage	380 Vac / 400 Vac / 440 Vac
Rated AC Grid Frequency	50 Hz / 60 Hz
Max. AC Current	139.8 A (LUNA2000 - 97KWH-1H1) / 173.2 A (LUNA2000 - 129/161KWH-2H1)
Adjustable Power Factor Range	-1 ... +1
Max. Total Harmonic Distortion	< 3%
Protection	
Anti-islanding Protection	Yes
AC Overcurrent Protection	Yes
DC Reverse-polarity Protection	Yes
Insulation Resistance Detection	Yes
Residual Current Protection	Yes
DC Surge Protection	Type II
AC Surge Protection	Type II
Communication	
Display	LED Indicators, WLAN + APP
Networking Mode	Ethernet, CAN
General	
Dimensions (W x H x D)	875 x 820 x 365 mm
Weight	< 95 kg
Operating Temperature Range	-25°C ~ 60°C (Derating above 40°C)
Cooling Method	Smart Air Cooling
Max. Operating Altitude without Derating	4,000 m
Relative Humidity	0 ~ 100%
DC Connector	OT/DT Terminal
AC Connector	OT/DT Terminal
Protection Degree	IP66
Topology	Transformerless

Typical System Configurations

Energy Volume kWh (Up to 3,870 kWh)	Recommended Combination of Models				
967.5					12 * 5p
935.3					12 * 4p + 10
903.0					12 * 4p + 8
870.8					12 * 4p + 6
838.5					12 * 3p + 8 * 2p
806.3					12 * 3p + 8 + 6
774.0				12 * 4p	
741.8				12 * 3p + 10	
709.5				12 * 3p + 8	
677.3				12 * 3p + 6	
645.0				12 * 2p + 8 * 2p	
612.8				12 * 2p + 8 + 6	
580.5			12 * 3p		
548.3			12 * 2p + 10		
516.0			12 * 2p + 8		
483.8			12 * 2p + 6		
451.5			12 + 8 * 2p		
419.3			8 * 3p		
387.0		12 * 2p			
354.8		12 + 10			
322.5		12 + 8			
290.3		12 + 6			
258.0		8 * 2p			
225.8		8 + 6			
193.5	12				
161.3	10				
129.0	8				
96.8	6				
Power (Up to 2000kW)	100 kW	200 kW	300 kW	400 kW	500 kW
Smart String ESS (Up to 20x)	1x	2x	3x	4x	5x

Note

1. The four capacity models can be used together. A maximum of 20 ESSs can be connected in parallel. This table only demonstrates the scenario where 5 or less ESSs are connected in parallel.
2. When different capacity models are connected in parallel, each ESS is charged and discharged according to its respective actual C rate.
3. 6, 8, 10 and 12 refer to the number of battery packs contained in different models, that is, LUNA2000-97KWH-1H1, LUNA2000-129KWH-2H1, LUAN2000-161KWH-2H1, LUNA2000-200KWH-2H1.
4. LUNA2000-161/129KWH-2H1, LUNA2000-97KWH-1H1 are not launched in Chinese Mainland and Japan.

LUNA2000-2.0MWH Series Smart String ESS



More Energy



Optimal Investment



Simple O&M



Safe & Reliable

Battery Container

Model	LUNA2000-2.0MWH-1H0	LUNA2000-2.0MWH-1H1	LUNA2000-2.0MWH-2H1
DC Rated Voltage	1,200 V	1,250 V	1,250 V
DC Max. Voltage	1,500 V	1,500 V	1,500 V
Nominal Energy Capacity	2,064 kWh	2,032 kWh	2,032 kWh
Charge & Discharge Rate	≤ 1 C	≤ 1 C	≤ 0.5 C
Rated Power	2,064 kW	2,032 kW	1,016 kW
Container Configuration (W x H x D)	6,058 x 2,896 x 2,438 mm	6,058 x 2,896 x 2,438 mm	6,058 x 2,896 x 2,438 mm
Container Weight	≤ 30 t	≤ 30 t	≤ 30 t
Operation Temperature Range	-30°C ~ 55°C	-30°C ~ 55°C	-30°C ~ 55°C
Storage Temperature Range	-40°C ~ 60°C	-40°C ~ 60°C	-40°C ~ 60°C
Relative Humidity	0 ~ 100% (Non-condensing)	0 ~ 100% (Non-condensing)	0 ~ 100% (Non-condensing)
Max. Operating Altitude	4,000 m	4,000 m	4,000 m
Cooling Method	Smart Air Cooling	Smart Air Cooling	Smart Air Cooling
Configuration of HVAC	8 HVACs ¹	8 or 6 HVACs ¹	6 or 4 HVACs ¹
Fire Suppression Agent	FM-200	FM-200 / Novec 1230™	FM-200 / Novec 1230™
Communication Interface	Ethernet / SFP	Ethernet / SFP	Ethernet / SFP
Communication Protocol	Modbus TCP / IEC 104	Modbus TCP / IEC 104	Modbus TCP / IEC 104
Protection Degree	IP55	IP55	IP55
Anti-corrosion Degree	C5-Medium	C5-Medium	C5-Medium
Black Start	-	Optional	Optional

Standards Compliance

RoHS, IEC62477-1, IEC62040-1, IEC61000-6-2, EN55011, UL9540A, IEC62619, UN3536, etc.

¹ - The quantity of HVACs depends on C rate and application scenario

LUNA2000-1.0MWH-1H1

Smart String ESS



More Energy



Optimal Investment



Simple O&M



Safe & Reliable

Battery Container

Model	LUNA2000-1.0MWH-1H1
DC Rated Voltage	1,250 V
DC Max. Voltage	1,500 V
Nominal Energy Capacity	1,016 kWh
Rated Power	1,016 kW
Container Configuration (W x H x D)	6,058 x 2,896 x 2,438 mm
Container Weight	≤ 20 t
Operation Temperature Range	-30°C ~ 55°C
Storage Temperature Range	-40°C ~ 60°C
Relative Humidity	0 ~ 100% (Non-condensing)
Max. Operating Altitude	4,000 m
Cooling Method	Smart Air Cooling
Configuration of HVAC	3 HVACs
Fire Suppression Agent	FM-200 / Novec 1230™
Communication Interface	Ethernet / SFP
Communication Protocol	Modbus TCP / IEC 104
Protection Degree	IP55
Anti-corrosion Degree	C5-Medium
Black Start	Yes

Standards Compliance

RoHS, IEC62477-1, IEC62040-1, IEC61000-6-2, EN55011, UL9540A, , IEC62619, UN3536, etc.

Battery Pack & Smart Rack Controller

Smart String ESS



Battery Pack

General

BESS Model	LUNA2000-2.0MWH-1H0	LUNA2000-2.0MWH-1H1/2H1 LUNA2000-1.0MWH-1H1
Cell Material	LFP	LFP
Pack Configuration	16S 1P	18S 1P
Rated Voltage	51.2 V	57.6 V
Nominal Capacity	320 Ah / 16.38 kWh	280 Ah / 16.13 kWh
Weight	≤ 140 kg	≤ 140 kg
Dimensions (W x H x D)	442 x 307 x 660 mm	442 x 307 x 660 mm



Smart Rack Controller

Battery Side

Rated Voltage	1,209.6 V
Operating Voltage Range	40 V ~ 1,400 V
Rated Power Voltage Range	1,075 V ~ 1,320 V
Min. Start Voltage	350 V

Bus Side

Max. DC Voltage	1,500 V
Rated Voltage	1,250 V
Rated Current	275.2 A
Rated Power	344,000 W

General

Dimensions (W x H x D)	600 x 270 x 820 mm
Weight	≤ 90 kg
Cooling Method	Smart Air Cooling
Protection Degree	IP66

LUNA2000-200KTL Series Smart PCS



Max. Efficiency 99%



Modular Design



IP66 Protection



Surge Arresters for
DC & AC



Ethernet
Communication



Smart Grid
Algorithm

Efficiency Curve

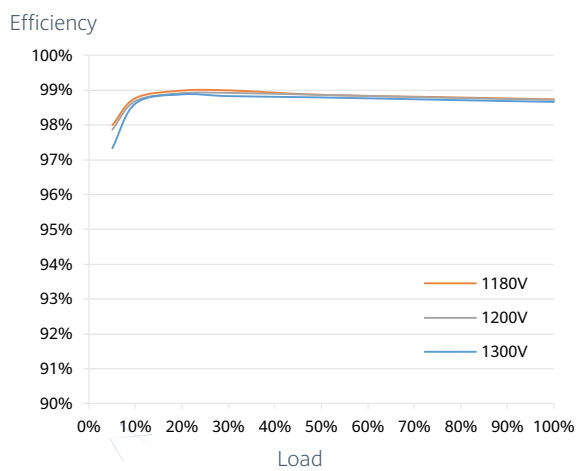

Circuit Diagram

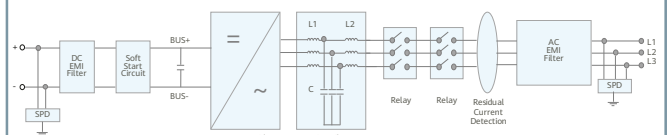

LUNA2000-200KTL Series

LUNA2000-200KTL Series Technical Specifications

Model	LUNA2000-200KTL-H0	LUNA2000-200KTL-H1
Efficiency		
Max. Efficiency	99.0%	
DC Side		
Rated DC Voltage	1,180 V	
Max. DC Voltage	1,500 V	
Operating DC Voltage Range	1,180 V ~ 1,500 V	
Max. DC Current	207.6 A	
Max. Number of Inputs	1	
AC Side		
Rated AC Active Power	200,000 W @40°C	
Rated AC Voltage	800 V	
Rated AC Grid Frequency	50 Hz / 60 Hz	
Max. AC Current	173.2 A	
Adjustable Power Factor Range	-1 ... +1	
Max. Total Harmonic Distortion	THD _i < 1% (Rated)	
Black Start	-	Yes
Protection		
AC Overcurrent Protection	Yes	
DC Reverse-polarity Protection	Yes	
Insulation Resistance Detection	Yes	
Residual Current Protection	Yes	
DC Surge Protection ¹	Type II	
AC Surge Protection ¹	Type II	
Communication		
Display	LED Indicators, WLAN + APP	
USB	Yes	
Ethernet	Yes	
General		
Dimensions (W x H x D)	875 x 820 x 365 mm	
Weight	< 99 kg	
Operating Temperature Range	-25°C ~ 60°C	
Cooling Method	Smart Air Cooling	
Max. Operating Altitude without Derating	4,000 m	
Relative Humidity	0 ~ 100% (Non-condensing)	
DC Connector	OT / DT Terminal	
AC Connector	OT / DT Terminal	
Protection Degree	IP66	
Anti-corrosion Degree	C5-Medium	
Topology	Transformerless	
Standards Compliance		
RoHS, IEC 62477-1, IEC 61000-6-2, IEC 61683, VDE 4120, EN 50549, etc.		

¹ - Compatible Type II protection class according to IEC / EN 61643-11

MERC-1100/1300W-P

Smart Module Controller



Higher Yields
Module-level Optimization
Increase System Energy
Yield by 5% to 30%



Flexible Design
Long String Design
to Reduce Bps



Active Safety
Safe Voltage Shutdown
Ensure Firefighting and
Maintenance Safety



Smart O&M
Pinpointing Open-
Circuit Fault for Quick
Troubleshooting

MERC-1100/1300W-P

Smart Module Controller

Technical Specification	MERC-1100W-P	MERC-1300W-P		
Input				
Rated Input DC Power ¹	1100 W			1300 W
Max. input voltage		125 V		
MPPT operating voltage range		12.5 – 105 V		
Max. short-circuit current (Isc)		20 A		
Max. efficiency		99.5 %		
Weighted efficiency		99.0 %		
Overvoltage category		II		
Output				
Max. output voltage		80 V		
Max. output current		22 A		
Output bypass ²		Yes		
Shutdown output voltage per optimizer ³		1 V		
Standards Compliance				
Safety		IEC62109-1 (class II safety)		
RoHS		Yes		
General Data				
Dimension (W x H x D)	149 mm x 104 mm x 49 mm (5.9 in. x 4.1 in. x 1.9 in.)			
Weight (including cables)	1.0 kg (2.2 lb.)			
Installation part (optional)	PV Module Frame Plate/T-shaped Bolt ⁴			
Input connector	Staubli MC4			
Input wire length	0.1 m (short input cable version) ⁵			
Output connector	Staubli MC4			
Output wire length	0.1 m (+), 5.1 m (-) (short input cable version) ⁵			
Operating temperature/humidity range	-40°C to +85°C ⁶ / 0%-100% RH			
Degree of protection	IP68			
Compatible Inverter	SUN2000-8/10/12/15/17/20KTL-M2 SUN2000-30/36/40KTL-M3 SUN2000-12/15/17/20/23/25KTL-M5 SUN2000-50KTL-M3			
String Configuration (Full Optimizer Configuration) ^{7/8/9} * MERC-1100/1300W-P support full optimizer configuration only	SUN2000-8~20KTL-M2	SUN2000-12~25KTL-M5	SUN2000-30~40KTL-M3	SUN2000-50KTL-M3
Minimum optimizers per string	8	8	8	8
Maximum optimizers per string	25	25	25	20
Maximum DC power per string	20,000 W	20,000 W	20,000 W	20,000 W

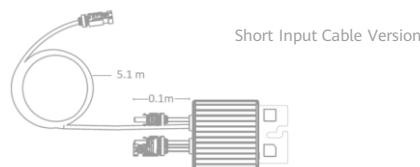

¹ The maximum power of PV module at STC shall NOT exceed the "Rated input DC power" of MERC -1100/1300W-P. PV Modules with up to +5% power tolerance are allowed.

² Any power optimizer, which is connected to an operating inverter in a PV string, will be bypassed when it fails.

³ When the MERC -1100/1300W-P is disconnected from inverter or when the inverter is off, its output voltage will be 1 V.

⁴ It is for PV module frame/extruded aluminum profile racking system installation.

⁵ Pay attention to PV module wire length. To match PV modules with a split junction box and short output wire, the long-input-cable version (input wire: 1.3 m(+/-); output wire 0.1m(+)/2.9m (-)) of MERC -1100/1300W-P is available upon request.

⁶ When the operating temperature of the MERC -1100/1300W-P reaches 70 °C to 85 °C, it may shut down due to over-temperature protection and report an over-temperature alarm. After the temperature decreases, it can automatically resume working without any damage.

⁷ Each PV module under the same inverter must be equipped with a MERC -1100/1300W-P.

⁸ SUN2000-450W-P2/600W-P and MERC -1100/1300W-P can NOT be used in mixture under the same Smart Energy/PV controller.

⁹ It is recommended that strings under the same inverter have an equal capacity. If it is not feasible, the capacity difference between strings under the same inverter must not exceed 2 kW. Otherwise, the energy yield will be reduced.

SUN2000-600W-P

Smart Module controller



Higher Yields

Module-level Optimization
Increase System Energy
Yield by 5% to 30%



Active Safety

Firefighting and O&M
Safety with Module-level
Rapid Shutdown



Flexible Design

Easier Module Layout
and 30% Higher Installed
Capacity on Average



Smart O&M

Module-level
Visibility and Refined
Management

Technical Specification		SUN2000-600W-P			
		Input			
Rated Input DC Power ¹		600 W			
Absolute maximum input voltage		80 V			
MPPT operating voltage range		10 - 80 V			
Maximum Short Circuit Current (Isc)		14.5 A			
Max. efficiency		99.5 %			
Weighted efficiency		99.0 %			
Overvoltage category		II			
		Output			
Max. output voltage		80 V			
Max. output current		15 A			
Output bypass ²		Yes			
Shutdown output voltage per optimizer ³		0 V			
Shutdown output impedance per optimizer		1k ohm ± 10 %			
		Communication			
Communication Method		MBUS			
		Standard Compliance			
Safety		IEC62109-1 (class II safety)			
RoHS		Yes			
		General Data			
Dimension (W x H x D)		75 x 140 x 28 mm (3.0 x 5.5 x 1.1 inch)			
Weight (including cables)		0.6 kg (1.3 lb.)			
Installation part (optional)		Frame Mounting Bracket / T-shaped Bolt ⁴			
Input connector		MC4			
Input wire length		0.15m (0.49 ft.)			
Output connector		MC4			
Output wire length		1.3 m (4.3 ft.) ⁵			
Operating temperature / humidity range		-40 °C ~ 85 °C ⁵ / 0 %RH ~ 100 %RH			
Degree of protection		IP68			
Compatible product		SUN2000-2/3/3.68/4/4.6/5/6KTL-L1, SUN2000-3/4/5/6/8/10KTL-M1, SUN2000-12/15/17/20KTL-M2, SUN2000-30/36/40KTL-M3			
Long String Design (Full Optimizer)		SUN2000-2-6KTL-L1	SUN2000-3-10KTL-M1	SUN2000-12-20KTL-M2	SUN2000-30-40KTL-M3
Minimum optimizer number per string ⁶		4	6	6	6
Maximum optimizer number per string		25	35	35	25
Maximum DC power per string		6,000 W	10,000 W	12,000 W	12,000 W

¹ In the STC environment, The rated power of the module shall not exceed 1.05 times of the optimizer rated input power.

² Power optimizer is bypassed in the string connected to an operating inverter when it fails to work

³ Power optimizer output 0Vdc when disconnecting to the inverter or inverter is shutdown.

⁴ Allow PV module frame installation / extruded aluminum profile installation

⁵ Fits PV module in landscape and portrait installation.

⁶ Require standard 60 cells module to meet the inverter minimum startup voltage

⁷ Full power capability refers to online smart design tool.

Smart Dongle-WLAN-FE



Smart

WLAN & Fast Ethernet (FE) communication
Support 3rd-party monitoring system ¹



Simple

Plug & Play
Support max. 10 devices



Reliable

IP65
Support auto reconnection

Technical Specification	SDongleA-05(AP+STA)
General Data	
Max. Devices Supported	10
Max. Inverters Supported	10
Connection interface	USB
Ethernet Interface	10/100M Ethernet
Installation	Plug-and-play
Indicator	LED Indicator
Dimensions (W * H * D)	146 x 48 x 33 mm (5.1 x 1.9 x 1.3 inch)
Weight	90 g (0.2 lb.)
Degree of protection	IP65
Power consumption (typical)	2.5 W
Operation Mode	AP + STA
Encryption Algorithm	Encryption Mechanism: WPA/WPA2 Encryption: TKIP/CCMP/AES
Wireless Parameter	
Supported standards & frequencies	802.11b/g/n (2.412G—2.484G)
Environment	
Operating temperature range	-30 °C to +65 °C (-22 °F to 149 °F)
Relative humidity range	5 - 95% RH
Storage temperature range	-40 °C to +70 °C (-40 °F to 158 °F)
Max. operating altitude	4,000 m (13,123 ft.)
Standard Compliance (more available upon request)	
Certificate	SRRC, CE, RCM
Inverter Compatibility	
Inverter Model	SUN2000-2/3/3.68/4/4.6/5/6-L1 SUN2000-3/4/5/6/8/10-M1 SUN2000-12/15/17/20KTL-M2 SUN2000-12/15/17/20/25KTL-M5 SUN2000-30/36/40/50KTL-M3 SUN2000-100/115KTL-M2 SUN2000-110KTL-INM2

¹: 3rd-party management system shall match the communication protocol with Huawei Smart Dongle.

Smart Dongle-4G



Smart

4G communication ¹

Support 3rd-party monitoring system ²



Simple

Plug & Play

WLAN-AP for local deploying ³



Reliable

IP65

Support auto reconnection

Technical Specification	SDongleB-06-EU	SDongleB-06-AU	SDongleB-06-NH
-------------------------	----------------	----------------	----------------

General Data	
Max. Devices Supported	10
Max. Inverters Supported	10
Connection interface	USB
Installation	Plug-and-play
Indicator	LED Indicator
Dimensions (W * H * D)	162*48*28mm
Degree of protection	IP65
Power consumption (typical)	3.5W

Wireless Parameter			
Sim card type	mini-sim (15 mm*25 mm)		
Supported standards & frequencies ⁴	LTE-FDD: B1/B3/B7/B8/B20/B28 LTE-TDD: B38/B40/B41 GSM: 850/900/1800/1900MHz	LTE-FDD: B1/B2/B3/B4/B5/B7/B8/B28 LTE-TDD: B40 WCDMA: B1/B2/B5/B8 GSM: 850/900/1800/1900MHz	LTE-FDD: B1/B3/B8/B18/B19/B26 LTE-TDD: B41 WCDMA: B1/B6/B8/B19
Wifi Operation Mode	AP		
Supported standards & frequencies	802.11b/g/n (2.412G—2.484G)		

Environment	
Operating temperature range	-30 °C to +65 °C (-22 °F to 149 °F)
Relative humidity range	5 - 95% RH
Storage temperature range	-40 °C to +70 °C (-40 °F to 158 °F)
Max. operating altitude	4,000 m (13, 123 ft.)

Standard Compliance (more available upon request)			
Certificate	CE	RCM	TELEC

Inverter Compatibility	
Inverter model	SUN600-5/6KTL-L0 SUN2000-2~6KTL-L1 SUN2000-3~10KTL-M1 SUN2000-8~20KTL-M2 SUN2000-12~25KTL-M5 SUN2000-20~50KTL-M3 SUN2000-50/60KTL-M0 SUN2000-50KTL-JPM1 SUN2000-63KTL-JPM0 SUN2000-75KTL-M1 SUN2000-100KTL-M0/M1 SUN2000-100KTL-INM0 SUN2000-110KTL-INM2 SUN2000-100/115KTL-M2

1: To ensure stable data transmission, Huawei suggests 4G dongle to be installed in areas with stable mobile signal (2G signal ≥ 4 bars, 3G/4G signal ≥ 3 bars).
 2: 3rd-party management system shall match the communication protocol with Huawei Smart Dongle.
 3: When all inverters support WLAN hotspot, hotspot of Dongle will be disabled by default.
 4: For recommended carriers list and details on supported frequencies, please contact local distributors.

SmartLogger3000A



Smart

Smart zero export control design



Simple

Easy to install on site



Reliable

Safety by lightning protection module

Technical Specification	SmartLogger3000A03EU	SmartLogger3000A01EU
Device Management		
Max. Number of Connected Devices	80	
Communication Interface		
WAN	WAN x 1, 10 / 100 / 1000 Mbps	
LAN	LAN x 1, 10 / 100 / 1000 Mbps	
RS485	COM x 3, 1200 / 2400 / 4800 / 9600 / 19200 / 115200 bps, 1000 m	
MBUS	MBUS x 1, 115.2 kbps, Compatible with PLC	No MBUS Communication Interface
2G / 3G / 4G ¹	LTE(FDD): B1,B2,B3,B4,B5,B7,B8,B20 DC-HSPA+/HSPA+/HSPA/UMTS: 850/900/1900/2100 MHz GSM/GPRS/EDGE: 850/900/1800/1900 MHz ²	
Digital / Analog Input / Output	DI x 4, DO x 2, AI x 4	
Active DO	12V, 100mA (connection with relay, sensor)	
Communication Protocol		
Ethernet	Modbus-TCP, IEC 60870-5-104	
RS485	Modbus-RTU, IEC 60870-5-103 (standard), DL / T645	
Interaction		
LED	LED Indicator x 3 – RUN, ALM, 4G	
WEB	Embedded Web	
USB	USB 2.0 x 1	
APP	Communication by WLAN for Commissioning	
Environment		
Operating Temperature Range	-40°C ~ 60°C (-40°F ~ 140°F)	
Storage Temperature	-40°C ~ 70°C (-40°F ~ 158°F)	
Relative Humidity (Non-condensing)	5% ~ 95%	
Max. Operating Altitude	4,000 m (13,123 ft.)	
Electrical		
AC Power Supply	100 V ~ 240 V, 50 Hz / 60 Hz	
DC Power Supply	12 V / 24 V	
Power Consumption	Typical 8 W, Max. 15 W	
Mechanical		
Dimensions (W x H x D)	225 x 160 x 44 mm (8.9 x 6.3 x 1.7 inch, without mounting ears and antenna)	
Weight	2 kg (4.4 lb.)	
Protection Degree	IP20	
Installation Options	Wall Mounting, DIN Rail Mounting, Tabletop Mounting	

^{*1}: When putting inside metal box, extended antenna will be needed.

^{*2}: For recommended carriers list and details on supported frequencies, please contact local distributors.

SmartACU2000D

Smart Array Controller



With SmartPID2000 Module



Without SmartPID2000 Module



Smart

Support one-click commissioning
Patented anti-PID module



Simple

SmartPID2000 & Smartlogger3000B
pre-installed with multiple interfaces



Reliable

Industrial-level application
and high reliability

Technical Specification	SmartACU2000D-D-00	SmartACU2000D-D-02	SmartACU2000D-D-01	SmartACU2000D-D-03
Configuration				
Smart Logger	SmartLogger3000B x 1			
SmartModule1000A	Optional			Standard with SmartModule1000A x 1
RS485	Supported			
No. of MBUS ¹	1	2	1	2
No. of SmartPID2000	0	0	1	2
Environment				
Operating Temperature Range	-40°C ~ 60°C (-40°F ~ 140°F)			
Relative Humidity	4% ~ 100%			
Max. Operating Altitude	4,000 m (13,123 ft.)			
Electrical				
AC Input Voltage for SACU	100 V ~ 240 V, L / N (L)+ PE			
AC Input Voltage for MBUS	380 V ~ 800 V, 3Ph			
AC Input Voltage for PID	380 V ~ 800 V, 3Ph + FE (Functional Earth)			
AC Input Frequency	50 / 60 Hz			
Power Supply	Standard: 12 V DC Optional: 24 V DC ²			
Mechanical				
Cable Entries	Bottom in & out			
Maintenance	Front			
Dimensions (W x H x D)	640 x 770 x 315 mm (25.2 x 30.3 x 12.4 inch)		880 x 770 x 369 mm (34.6 x 30.3 x 14.5 inch)	
Weight	29 kg (63.9 lb.)	32 kg (70.5 lb.)	49 kg (108.0 lb.)	61 kg (134.5 lb.)
Protection Degree	IP65			
Installation Options	Wall Mounting, Rack Mounting, Pole Mounting			

1. Compatible with communication mode of PLC (Power Line Communication).
2. 24V DC power supply is optional to power devices that require 24Vdc input and output.

Smart Power Sensor



Accurate

Class 1 measurement accuracy



Simple & Easy

LCD display, easy to set and check



Energy Efficient

Overall power consumption ≤ 1 W

Technical Specification	DDSU666-H	DTSU666-H	DTSU666-H 250A/50mA
General Data			
Dimension (H x W x D)	100 x 36 x 65.5 mm (3.9 x 1.4 x 2.6 inch)	100 x 72 x 65.5 mm (3.9 x 2.8 x 2.6 inch)	100 x 72 x 65.5 mm (3.9 x 2.8 x 2.6 inch)
Mounting type	DIN35 Rail		
Weight (including cables)	1.2 kg (2.6 lb)	1.5 kg (3.3 lb)	1.5 kg (3.3 lb)
Power Supply			
Power grid type	1P2W	3P3W/3P4W	3P3W/3P4W
Input voltage (phase voltage)		176 Vac ~ 288 Vac	
Power consumption	≤ 0.8 W	≤ 1 W	≤ 1 W
Measurement Range			
Line voltage	/	304 Vac ~ 499 Vac	304 Vac ~ 499 Vac
Phase voltage		176 Vac ~ 288 Vac	
Current	0 ~ 100 A	0 ~ 100 A	0 ~ 250 A
Measurement Accuracy			
Current / Voltage	± 0.5 %		
Power / Energy	± 1 %		
Frequency	± 0.01 Hz		
Communication			
Interface	RS485		
Baud rate	9,600 bps		
Communication protocol	Modbus-RTU		
Environment			
Operating temperature range	-25 °C ~ 60 °C		
Storage temperature range	-40 °C ~ 70 °C		
Operating humidity	5 %RH ~ 95 %RH (non-condensing)		
Others			
Accessories	RS485 Cable (10 m / 33 ft.)		
	1 CT 100A / 40mA (5 m / 16.4 ft.)	3 CT 100A / 40mA (5m / 16.4 ft.)	3 CT 250A / 50mA (5m / 16.4 ft.)

Smart Power Sensor



Accurate

Class 1 measurement accuracy



Simple & Easy

LCD display, easy to set and check



Energy Efficient

Overall power consumption ≤ 1.5 W

Technical Specification	DTSU666-HW/YDS60-80
General Data	
Dimension (H x W x D)	100 x 72 x 80 mm (3.9 x 2.8 x 3.1 inch)
Mounting type	DIN35 Rail
Weight (including cables)	< 0.5 kg
Power Supply	
Power grid type	3P4W/3P3W
Input voltage (line voltage)	90 ~ 500 Vac
Power consumption	≤ 1.5 W
Measurement Range	
Line voltage	90 Vac ~ 1000 Vac (> 500 with external PT ¹)
Phase voltage	52~577 Vac
Current	0 ~ 80 A(>80 with external CTs ²)
Measurement Accuracy	
Voltage / Current	± 0.5 %
Power / Energy	± 1 %
Frequency	± 0.01 Hz
Communication	
Interface	RS485
Baud rate	4800/9600/19200/115200 (Default 9600bps)
Communication protocol	Modbus-RTU
Environment	
Operating temperature range	-25 °C ~ 60 °C
Storage temperature range	-40 °C ~ 70 °C
Operating humidity	5 %RH ~ 95 %RH (non-condensing)
Others	
Accessories	RS485 Cable (10 m / 33 ft.)

*1 2nd voltage of CT should be 100V. And accuracy should be better than Class 0.5
 *2 2nd current of CT should be 1A or 5A. And accuracy should be better than Class 0.5

FusionSolar Smart PV Management System



Better experience

- One APP for all access procedure
- Auto-definition of local components
- Module auto-mapping within 5s



Energy visualization

- KPI Dashboard, centralized management of multiple plants
- Module-level monitoring
- Report subscription and real-time alarm push



Smart O&M

- One-screen mgmt. of site, personnel, status
- One-click ticket dispatching & site navigation
- Online Smart I-V Curve Diagnosis, 15mins required for a 100MW plant diagnosis

Networking

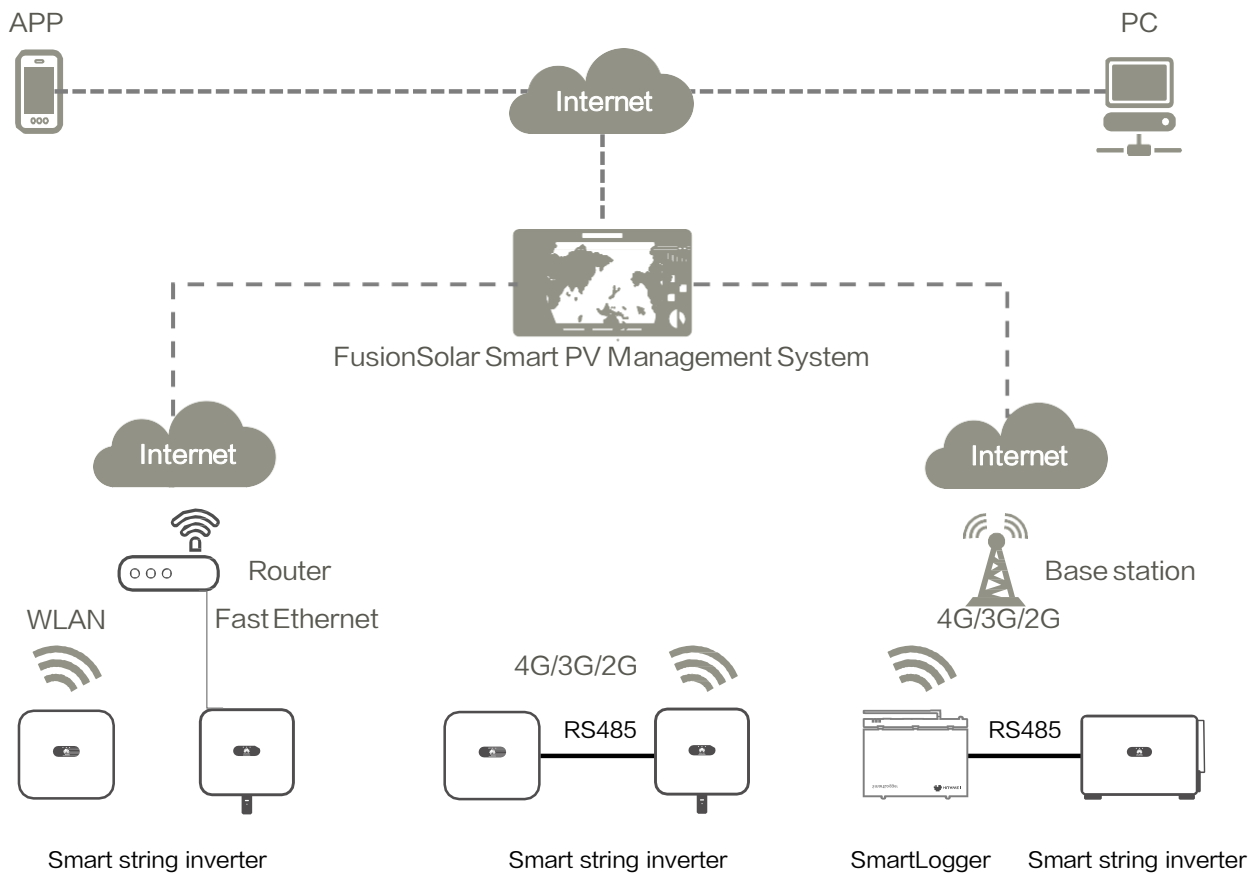

FusionSolar Smart PV Management System

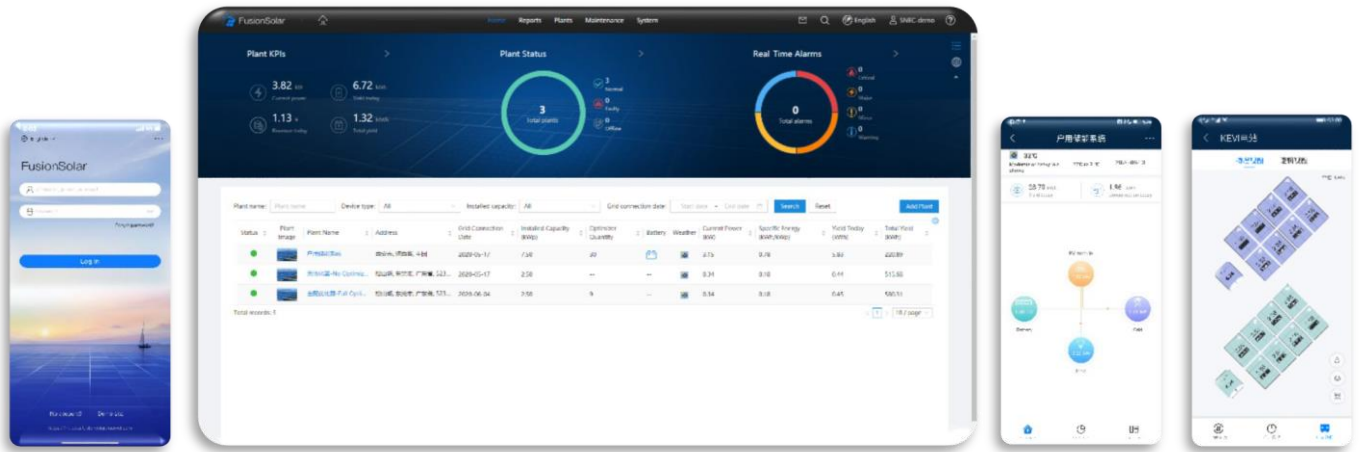

Category	Function	Web	APP
Homepage	PV Plants List	●	●
	Add Plant	●	●
Report Management	Plant Report	●	
	Inverter Report	●	
	Battery Report	●	
Device Management	Device Details	●	●
	Remote Parameter Setting	●	
	Remote Optimizer Search	●	
Intelligent O&M	Real-time Status	●	
	Alarm Management	●	●
	Task Management	●	●
	Smart IV-Curve Diagnose	●	
KPI Dashboard	KPI Dashboard	●	
Homepage of Single Plant	Energy Flow	●	●
	Energy Management	●	●
	Plant Layout	●	●
	Kiosk Mode	●	
System Setting	Plant Management	●	●
	Company Management	●	
Demo	Demo Site	●	●

Smart I-V Curve Diagnosis

Smart I-V Curve Diagnosis is able to carry out online I-V curve analysis on entire strings with advanced diagnosis algorithm. The scanning would help to find out and identify the strings with low performance or faults, which would help to achieve proactive maintenance, higher O&M efficiency and lower operation cost.

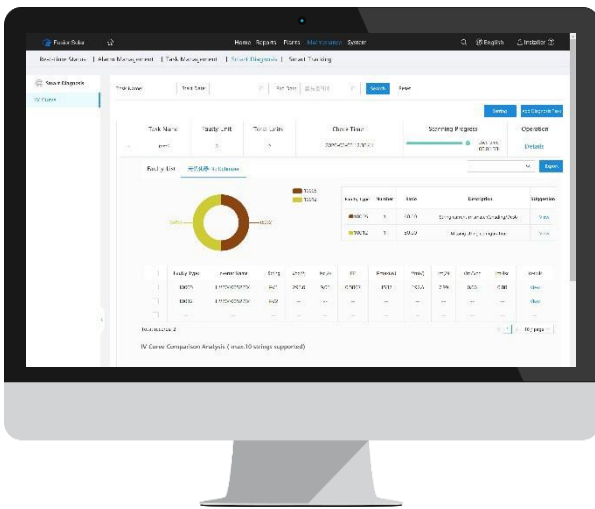

Smart

- Support plant-level, array-level and inverter-level analysis and diagnosis
- Automatically identify different failure types and provide recovery suggestion



Efficient

- One-click scanning without onsite experts or equipment
- Online I-V curve scanning on entire strings of 5 MW plant within 5min
- Automatic report generation of 5 MW plant within 15min

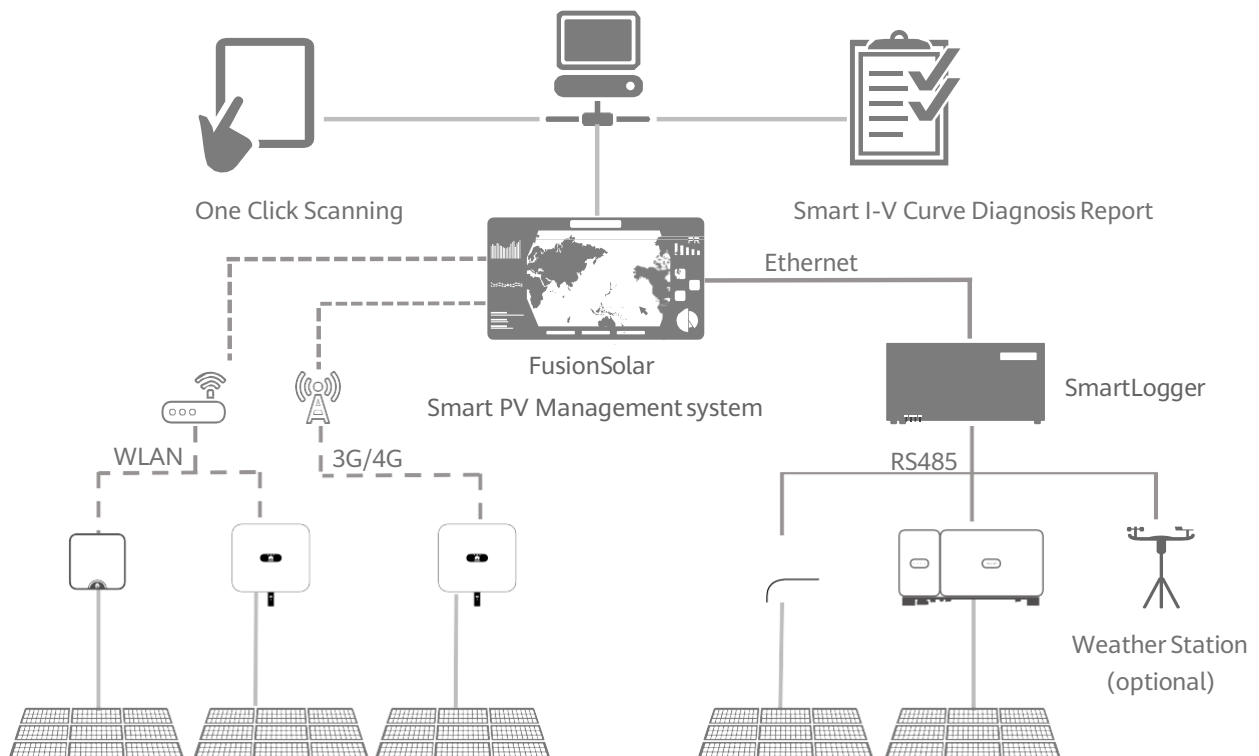

Network



Smart I-V Curve Diagnosis

Technical Specifications	Smart I-V Curve Diagnosis
Smart PV Inverter	SUN2000-2/3/3.68/4/4.6/5/6KTL-L1*, SUN2000-3/4/5/6/8/10KTL-M0, SUN2000-12/15/17/20KTL-M0, SUN2000-33KTL-A/36KTL, SUN2000-60KTL-M0, SUN2000-100KTL-M1
Communication	SmartLogger3000A, Smart Dongle-WLAN-FE/4G
Management System	FusionSolar Smart PV Management System, NetEco1000s
Scanning Time	< 1s (1 string)
Sampling Points per I-V Curve	128
Certification	 TÜVRheinland® TÜV

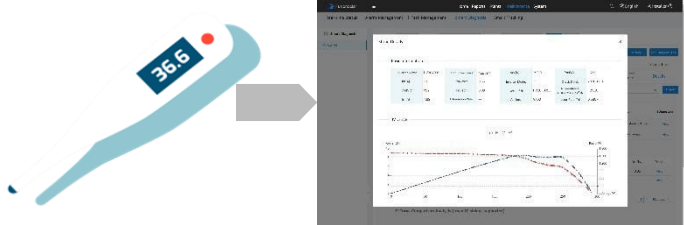
* I-V curve diagnosis is not supported when inverter is connected with power optimizer.

String-level Management	Smart I-V Curve Diagnosis
 <p>Real time monitoring</p>	 <p>Fault Analysis</p>

String I-V Curve Comparison

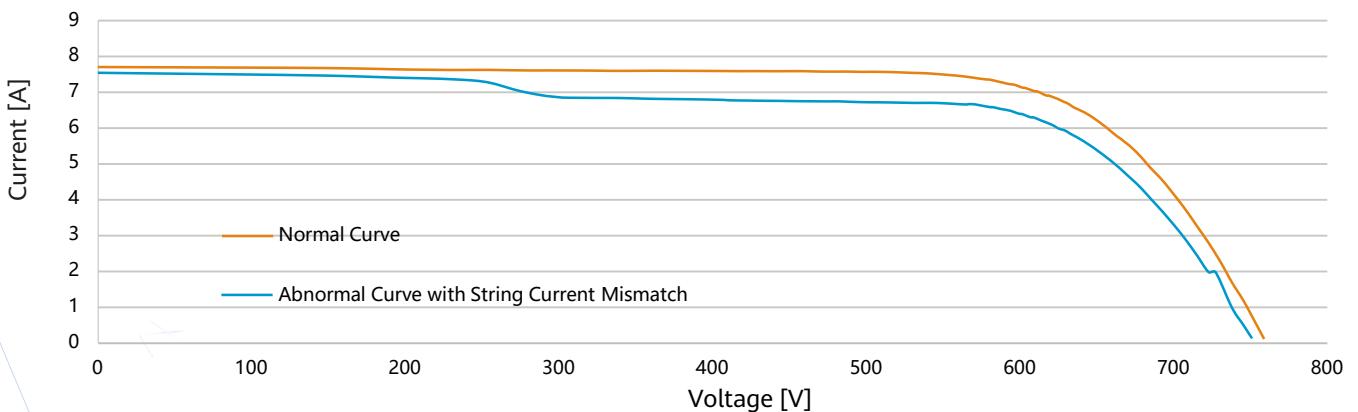
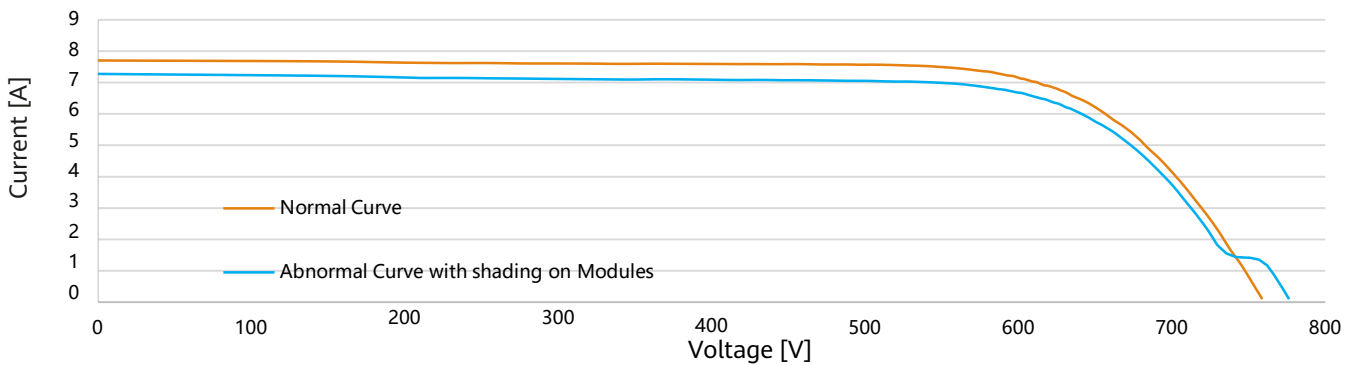



85.8KWp

Distributed PV System in Brazil

System Configuration

- 264 x 325Wp modules
- 2 x SUN2000-36KTL

COD
Feb, 2018



2.8MWp

Distributed PV system at Singapore Changi Airport

System Configuration

- SUN2000-36KTL

COD
Dec, 2016



1MWp

Distributed PV System in Kuala Lumpur, Malaysia

System Configuration

- SUN2000-36KTL

COD

Mar 2016



1.25MWp

Distributed PV System in South Africa

System Configuration

- SUN2000-60KTL

COD

Sep, 2019



200kWh ESS Program of Charging Station in Zhejiang, China

System Configuration

- LUNA2000-200KWH

COD
Oct 2022



11.6MWp Shera Rooftop Program Saraburi, Thailand

System Configuration

- SUN2000-60KTL

COD
Mar, 2020



1.1MWp

Shanghai Xinguo Food Factory Model Site,
China

System Configuration

- SUN2000-40KTL
- SUN2000-600W-P

COD
Jul 2022



131kWp+200KWH

PV Energy Storage EV Charger
Swapping Demo Station, Shenzhen

System Configuration

- SUN2000-50/60KTL
- LUNA2000-200KWH



COD
May, 2023



Copyright © Huawei Technologies Co., Ltd.2020 All rights reserved.

No part of this document may be reproduced or transmitted in any form or by any means without prior written consent of Huawei Technologies Co., Ltd.

Trademark Notice

 , HUAWEI and  are trademarks or registered remarks of Huawei Technologies Co., Ltd. Other trademarks, product service and company names mentioned are the property of their respective owners.

General Disclaimer

The information in this document may contain predictive statements including, without limitation, statements regarding the future financial and operating results, future product portfolio, new technology, etc. There are a number of factors that could cause actual results and developments to differ materially from those expressed or implied in the predictive statements. Therefore, such information is provided for reference purpose only and constitutes neither an offer nor an acceptance. Huawei may change the information at any time without notice.

HUAWEI TECHNOLOGIES Dusseldorf GmbH
Südwestpark 37,90449 Nürnberg, Deutschland
Hotline: +80 03 38 88 888
Email: eu_inverter_support@huawei.com

HUAWEI TECHNOLOGIES CO., LTD.
Huawei Industrial Base, Bantian Longgang
Shenzhen 518129, P.R. China
Tel: 400-822-9999
Version No.: 04-(20201006)
solar.huawei.com